



17562.0095.1 REV1

# **Spare parts list series Parva 2010**

## **Edition 05/2010**



# Spare parts list

## 1 REPLACEMENT PARTS CATALOGUE

This catalogue includes all the replacement parts required for the maintenance and service of boilers. This edition of the catalogue supersedes all previous editions.

## 2 MODELS AND SPECIFICATIONS

produces a number of boilers to satisfy a wide range of user needs and installation requirements.

All boilers are wall mounted, with instantaneous operation and modulating heat regulation; that is, the amount of heat from gas combustion is automatically varied according to the heat required by the heating system.

boilers differ in four basic characteristics:

### 2.1 Maximum useful heating power during operation as a building heat source

Two models are available with different maximum useful heating power when used as a building heat source. Each of these models is identified by its own model number:

*Models 24 (24kW), 28 (28kW), 32 (32kW)*

### 2.2 Fume exhaust method

The fumes in the combustion chamber can be exhausted in one of two different ways:

*A – Natural drafting (by the atmosphere)*

boilers using this system must be connected to an adequately-sized exhaust duct system (chimney), and use air from the installation area for combustion. Boilers using this system are identified by the letter "A" in their model number.

*B – Forced exhaust from a sealed combustion chamber*

These boilers are equipped with a fan which forces the fumes through an adequately-sized exhaust duct system; however, the combustion chamber is enclosed in a sealed chamber and is isolated from the installation area. Boilers using this system are identified by the letter "C" in their model number, and do not use air from the installation area for combustion.

## 3 MODEL IDENTIFICATION CODE/SERIAL NUMBER

Every boiler produced by carries its own model identification code/serial number.

It is important for the service centre to mention this number when contacting the factory (the number must be listed on guarantee claims and service reports; when making requests for technical information, etc.).

The following is a breakdown of the model identification code/serial number and its meaning (reading from left to right):

- A) The maximum useful heating power during operation as a building heat source.
- B) The type of boiler according to its functions
- C) The type of gas used by this boiler. The letter "N" is used for Natural gas; the letter "G" is used for liquefied petroleum gas (LPG).
- D) The first five numbers are the actual serial number.
- E) The last four numbers indicate the month (first two numbers) and the year of construction.

**These numbers are used in this catalogue to distinguish between versions of the same model with different modifications.**

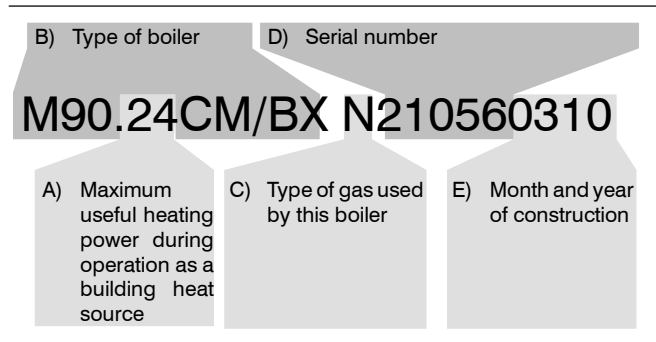

## 4 REPLACEMENT PARTS CODE

Each currently available replacement part is uniquely identified by its own replacement parts code. The replacement parts code consists of a table code and a position code.

### 4.1 Table code

The table code is a sequence of letters and numbers which uniquely and clearly identify each table. The table code can be found on the upper right of each table (see 4.3).

A validity chart for the table is located at the bottom of the table. This chart lists the models covered by the table.

M90.24CM/BX	M90.24A/BX	
M90.28CM/BX	M90.28A/BX	
M90.32CM/BX		

### 4.2 Position Code

The position code is a number which is used to identify a particular object on the table.

To make identification easier, position codes for kits have a different format from position codes for individual parts.

515	Position code for a kit (or assembly)	Position code for an individual part	125
-----	---------------------------------------	--------------------------------------	-----

A label can be found next to the position code. This label is used to provide additional information on the replacement part and makes identification of the part easier:

<i>A – Type of gas</i>		
515 <sub>G20</sub>	125 <sub>G20</sub>	G20 = Natural gas
515 <sub>G30–G31</sub>	125 <sub>G30–G31</sub>	G30 – G31 = Butane–Propane (LPG)

### *B – Validity restrictions*

515 <sub>(24)</sub>	125 <sub>(24)</sub>	For model 24 KW, only
515 <sub>(C)</sub>	125 <sub>(C)</sub>	For models (M90.24CM/BX, M90.28CM/BX, M90.32CM/BX), only

### 4.3 Composition of the replacement part code

Each replacement part code includes a table identification code and a position code. A position code is only listed for replacement parts which are currently available.

The replacement part code consists of the table code (which can be found on the upper right of the table) plus the position code (in two formats: individual part or kit).

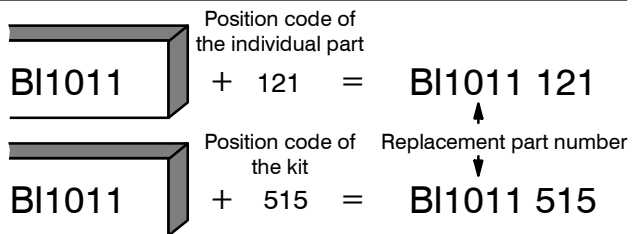

The components of a kit are enclosed in a broken line. A kit may contain other complete kits, or portions of other kits.

In some tables, a replacement part may be identified with an arrow and a complete replacement part code (table code + position code). This means that the part is available, but must be ordered with the code listed. Also, any explanatory notes must be read before ordering.

---

=BI1011 515  
 =BI1011 515  
 (24)  
 =BI1011 516  
 (28)

---

#### 4.4 Using the replacement parts code

The replacement parts code must be included on all documents which are used in service reports, orders for replacement parts, guarantee claims, etc.

## Spare parts list

<b>Table</b>		<b>Edition</b>	<b>N° of pages</b>
BI1411 Part 1	Water group	0510	1
BI1421 Part 1	Water group	0510	1
BI1462 Part 2	Water group	0510	1
BI1472 Part 2	Water group	0510	1
BI1183 Part 3	Gas group	0510	1
BI1193 Part 3	Gas group	0510	1
BI1323 Part 3	Gas group	0510	1
BI2015 Part 5	Driving panel and electric parts	0510	1
BI2025 Part 5	Driving panel and electric parts	0510	1
BI2055 Part 5	Driving panel and electric parts	0510	1
BI1346 Part 6	External panels, fire chamber	0510	1
BI1376 Part 6	External panels, fire chamber	0510	1
BI1506 Part 6	External panels, fire chamber	0510	1
BI1566 Part 6	External panels, fire chamber	0510	1
BI1911 Part 1	Spares	0510	1

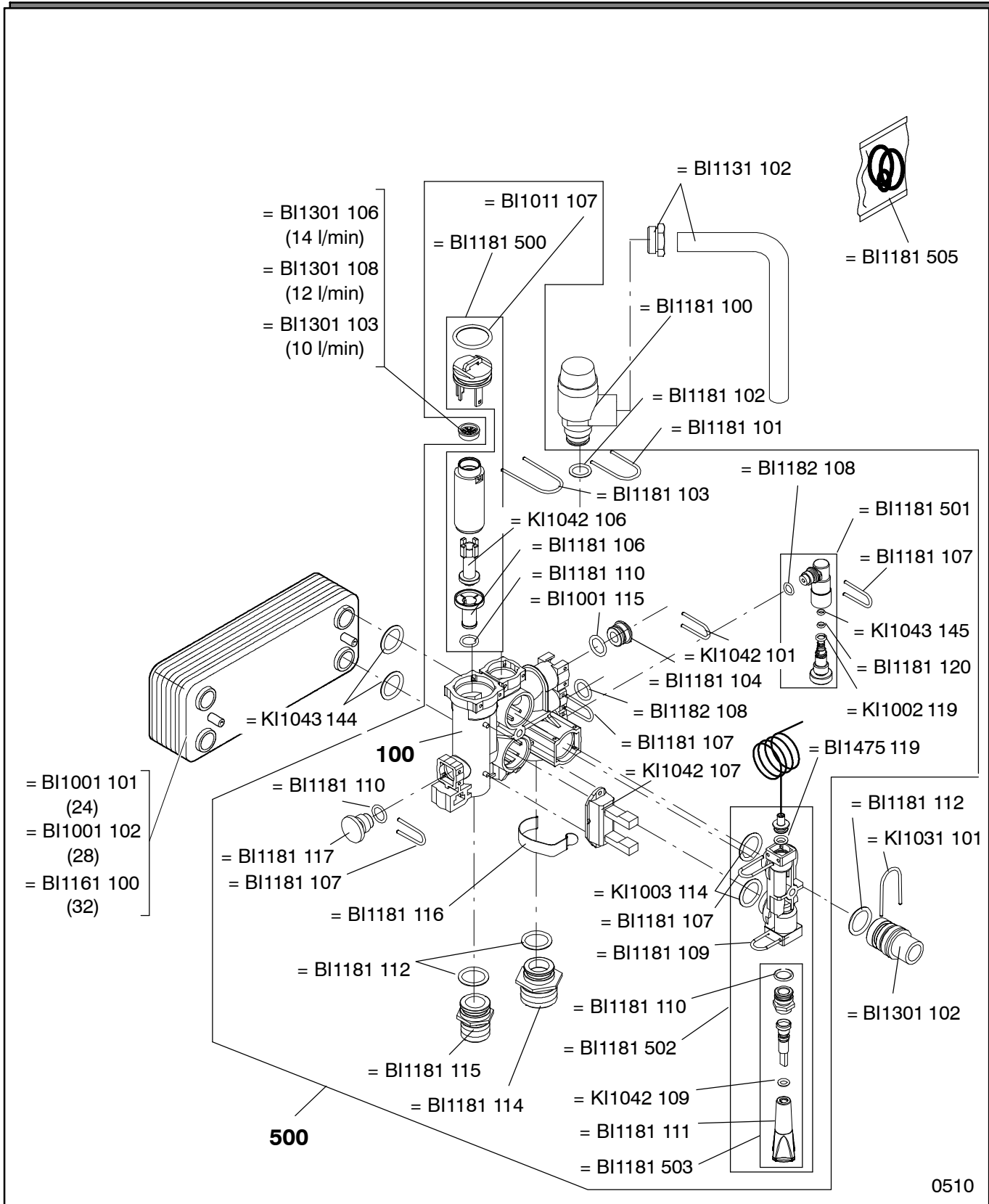

0510

M90.24CM/BX	M90.24A/BX			
M90.28CM/BX	M90.28A/BX			
M90.32CM/BX				



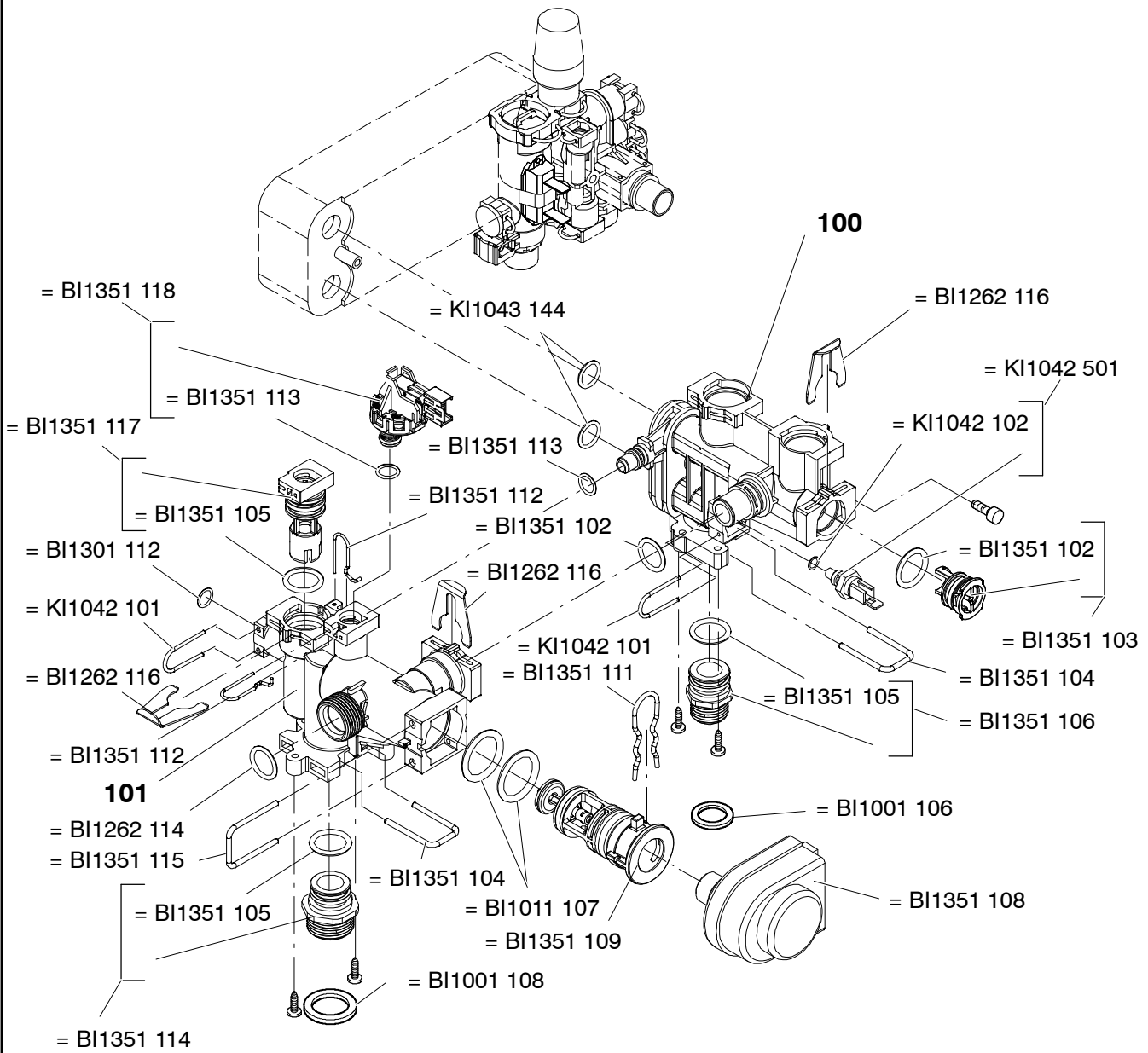

M90.24CM/BX	M90.24A/BX			
M90.28CM/BX	M90.28A/BX			
M90.32CM/BX				



Part 2 - Water group

BI1462

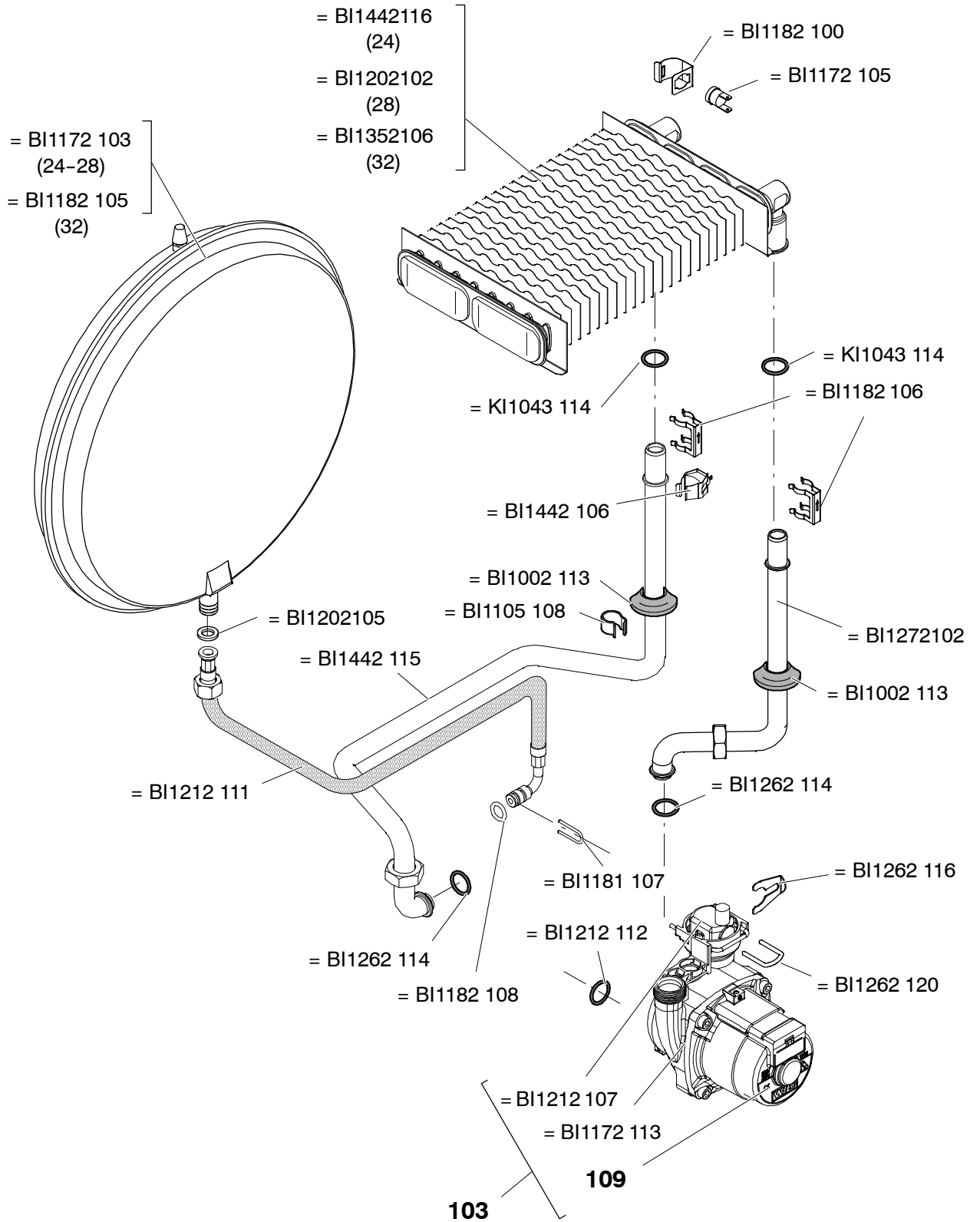

0510

M90.24CM/BX				
M90.28CM/BX				
M90.32CM/BX				



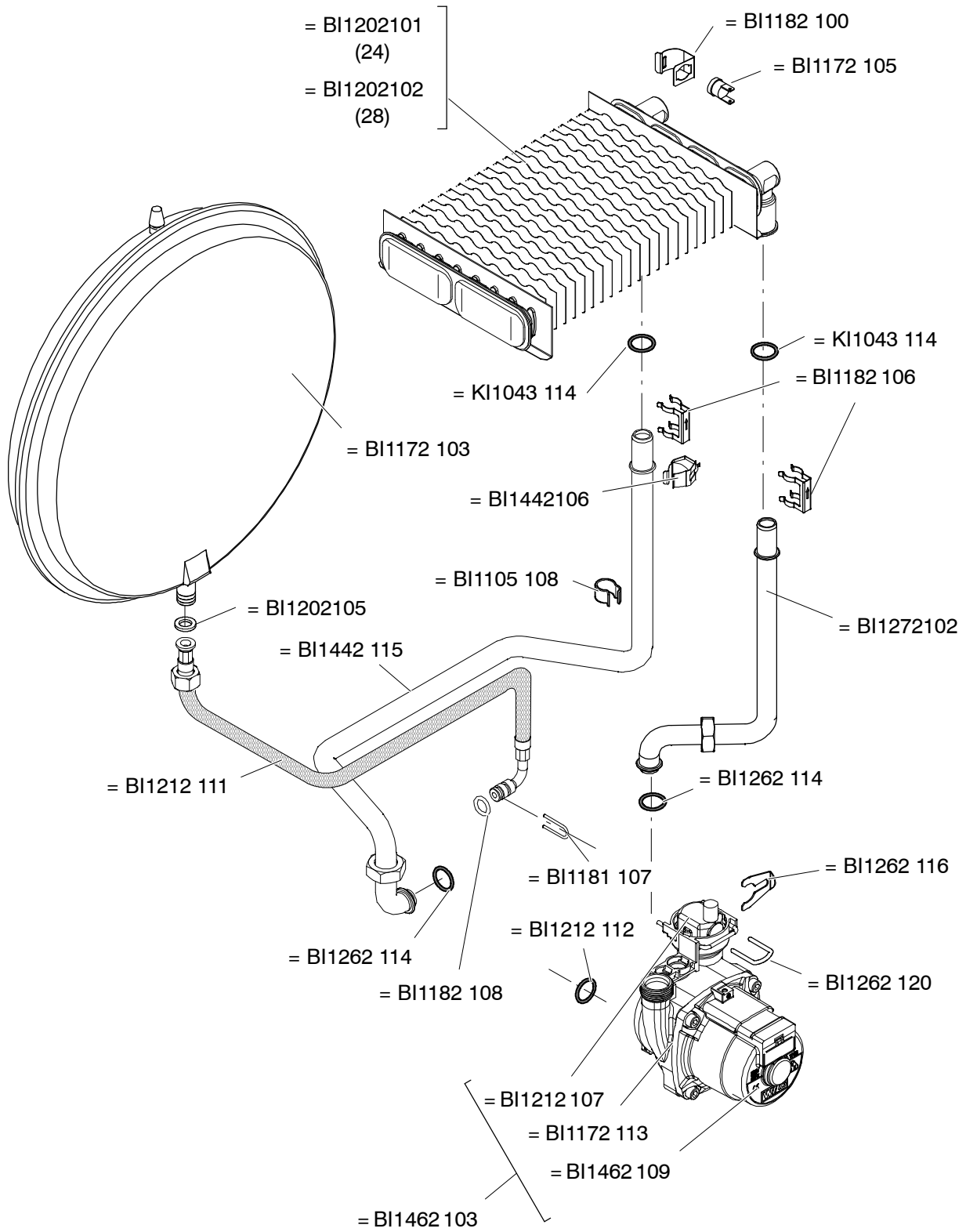

0510

	M90.24A/BX			
	M90.28A/BX			



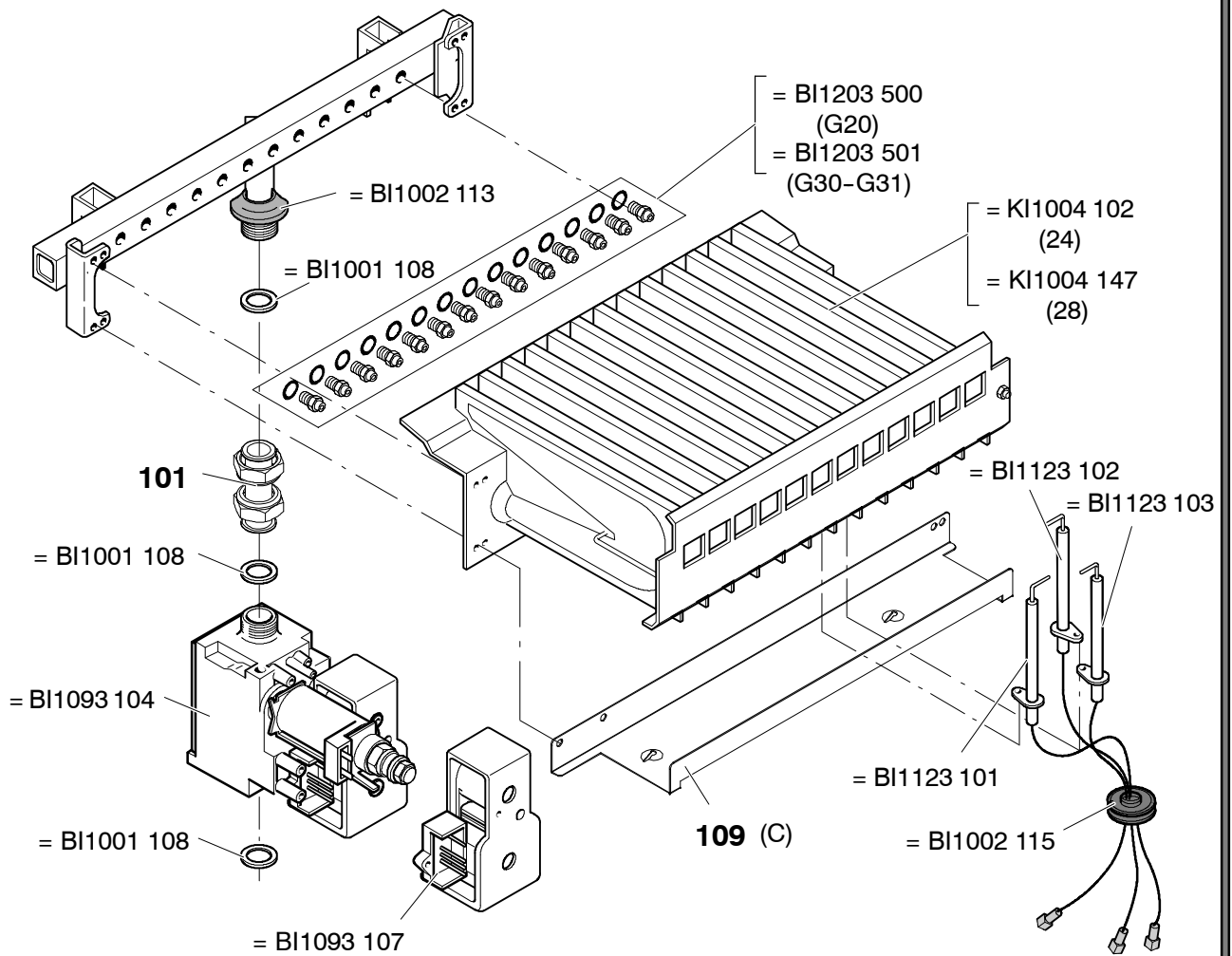

0510

	M90.24A/BX			
M90.28CM/BX	M90.28A/BX			



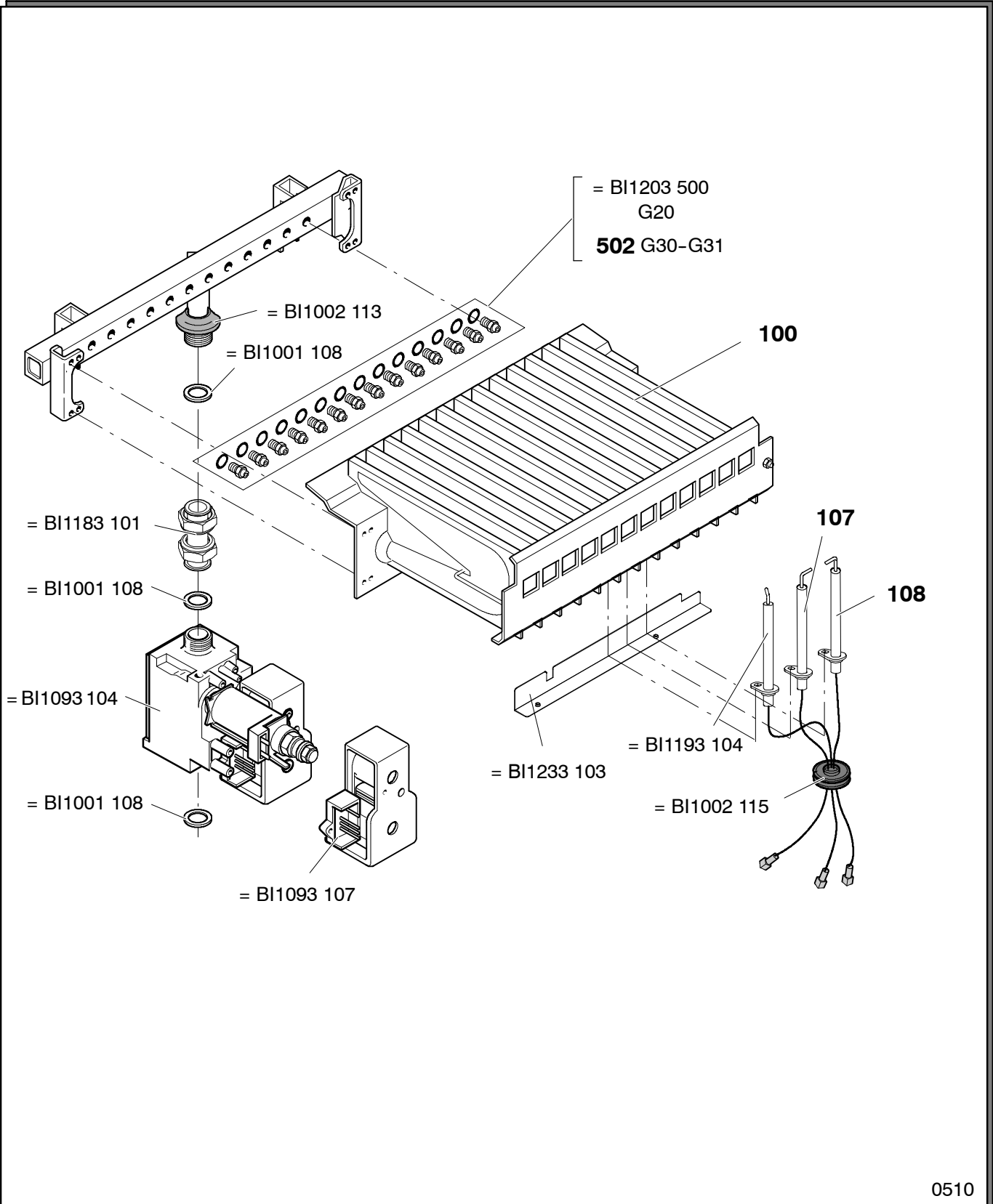

M90.24CM/BX				



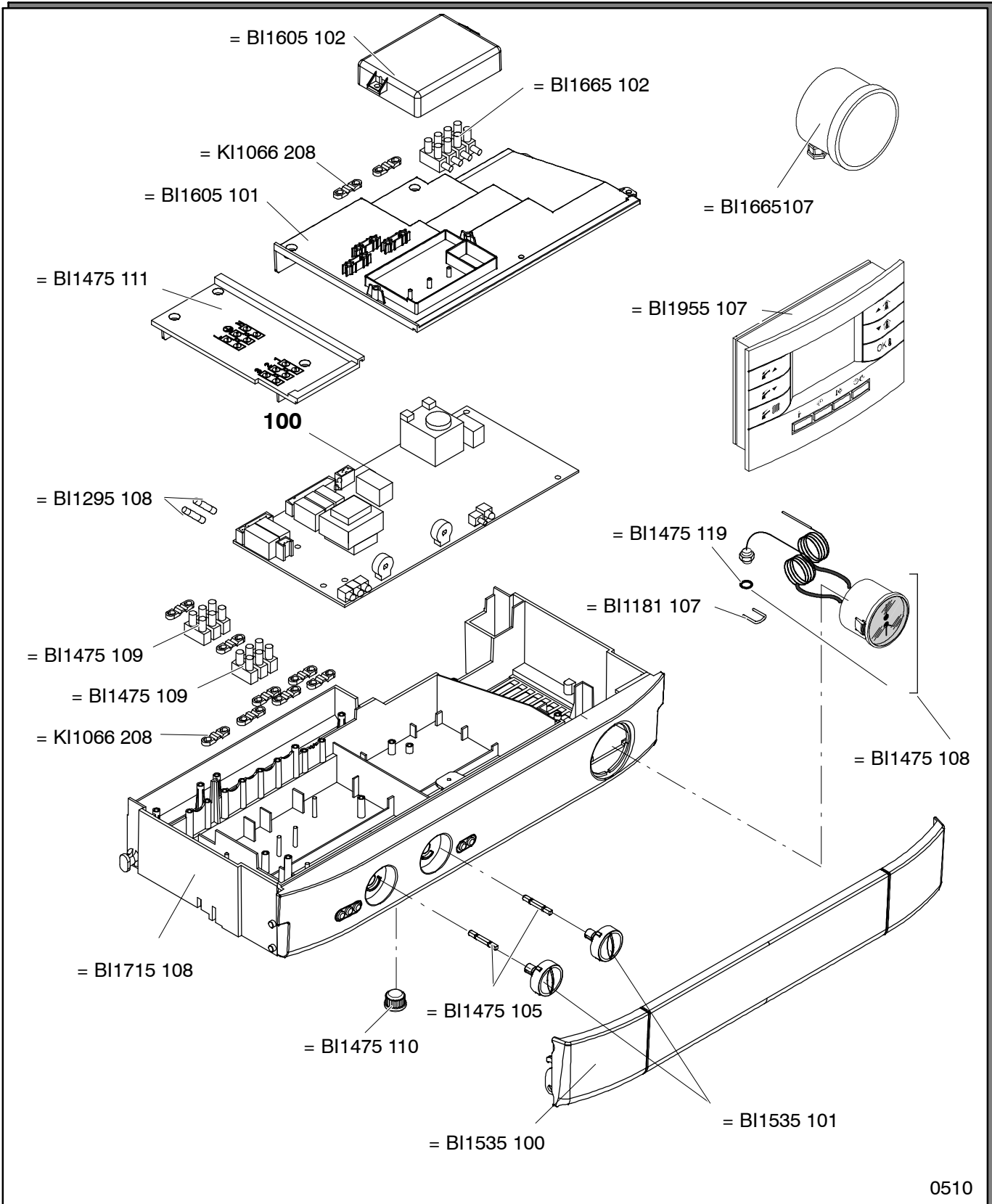

0510

M90.24CM/BX	M90.24A/BX				
M90.28CM/BX	M90.28A/BX				
M90.32CM/BX					

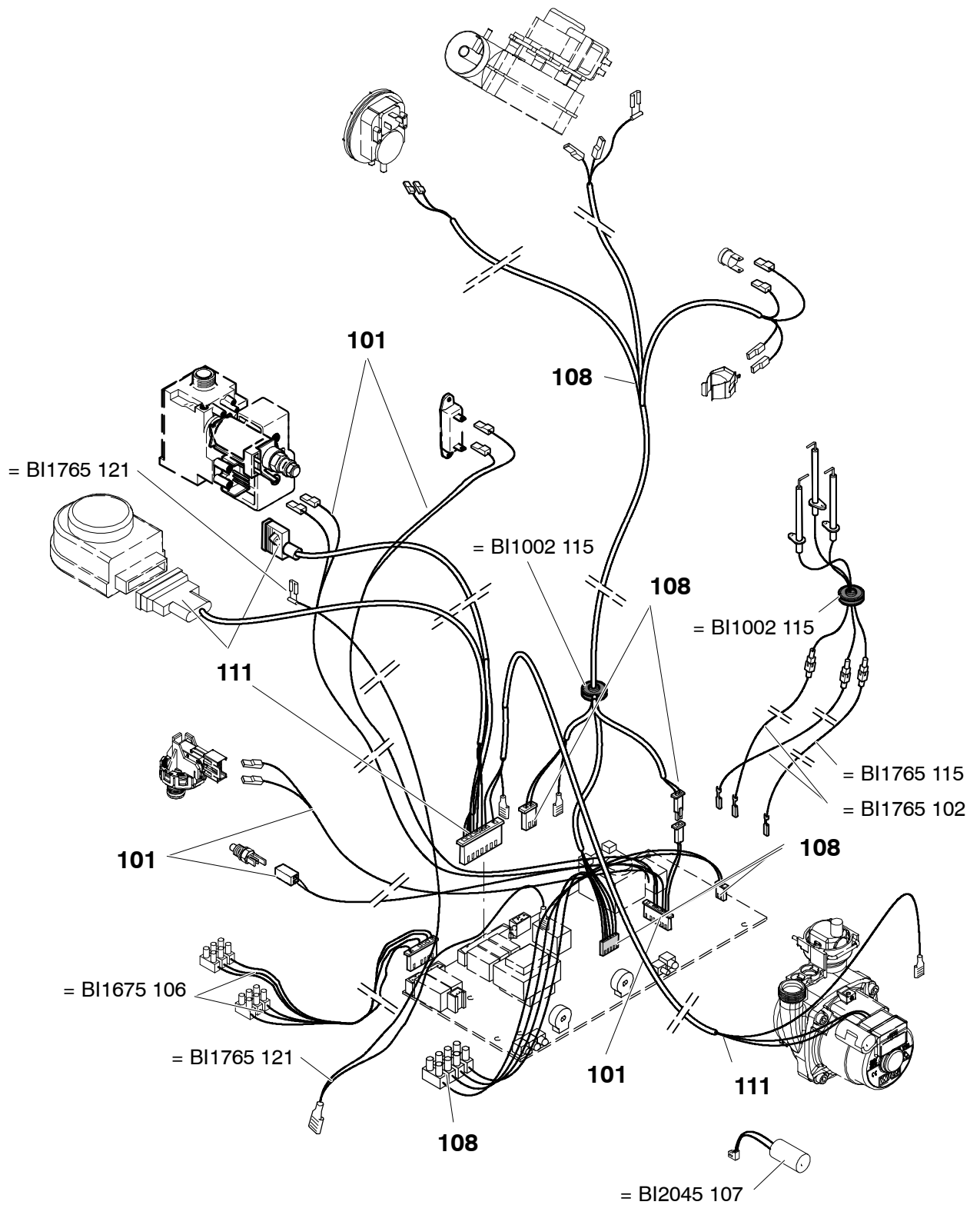

0510

M90.24CM/BX				
M90.28CM/BX				
M90.32CM/BX				



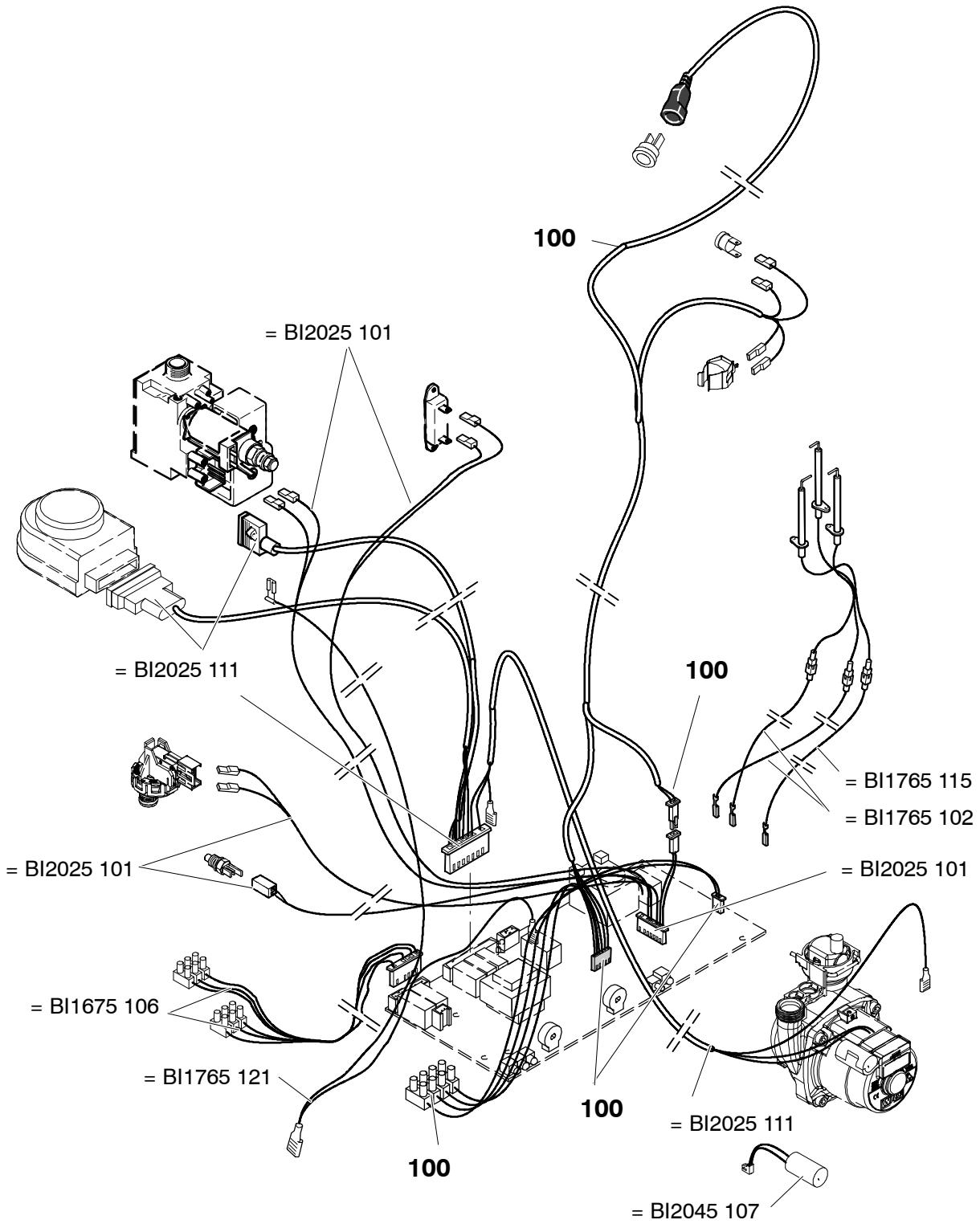

0510

	M90.24A/BX			
	M90.28A/BX			



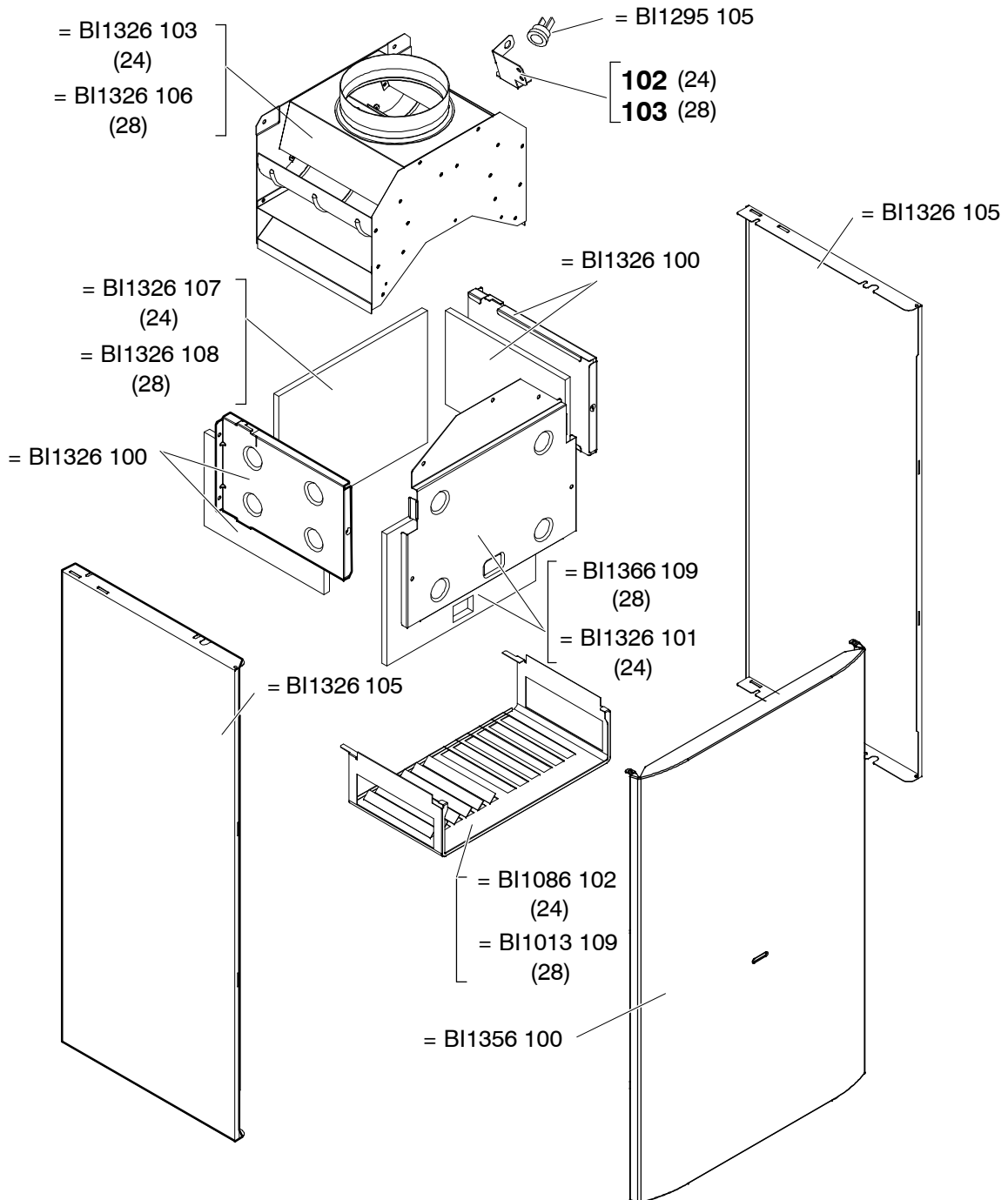

0510

	M90.24A/BX			
	M90.28A/BX			

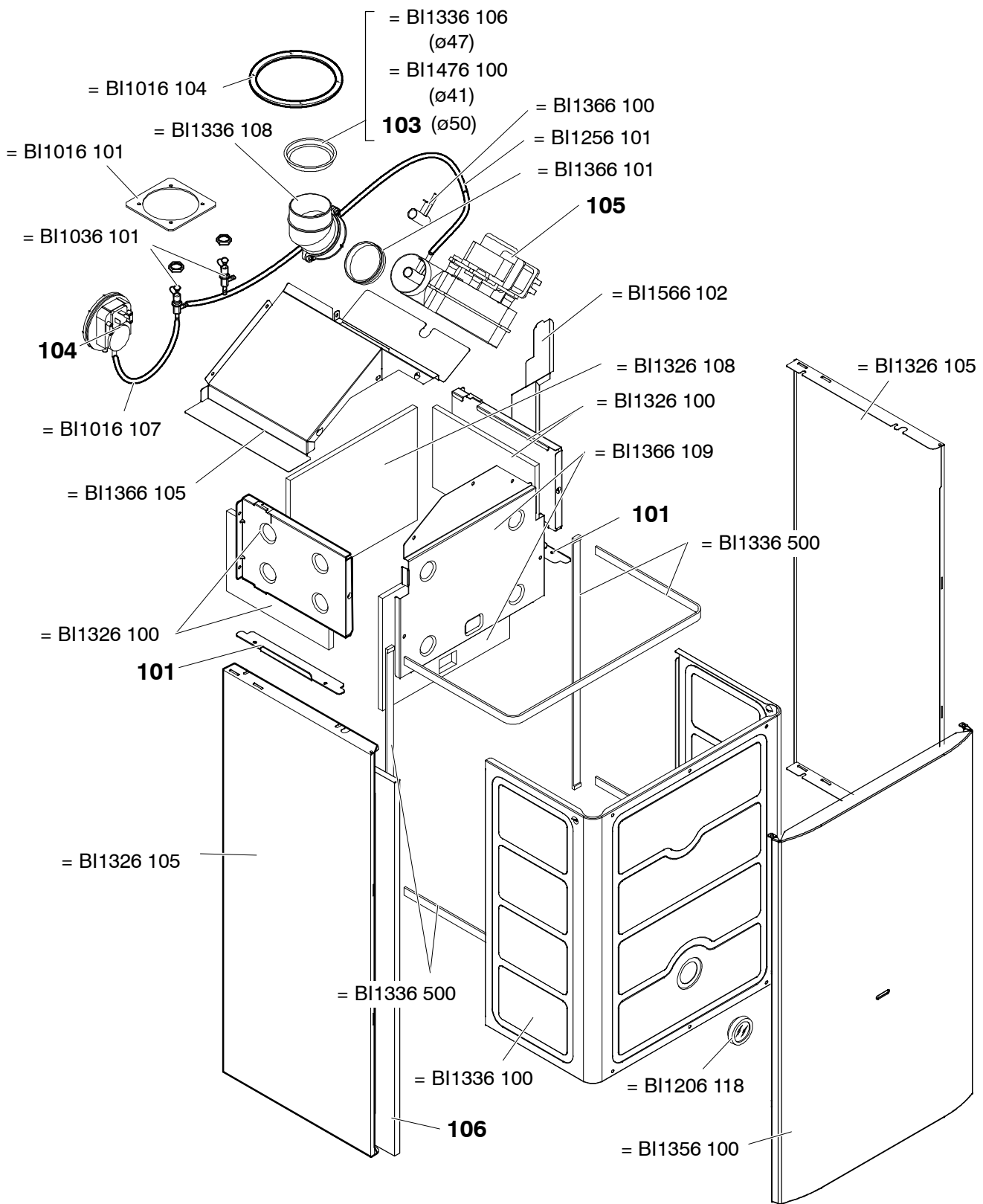

0510

Part 6 - External panels, fire chamber

BI1506

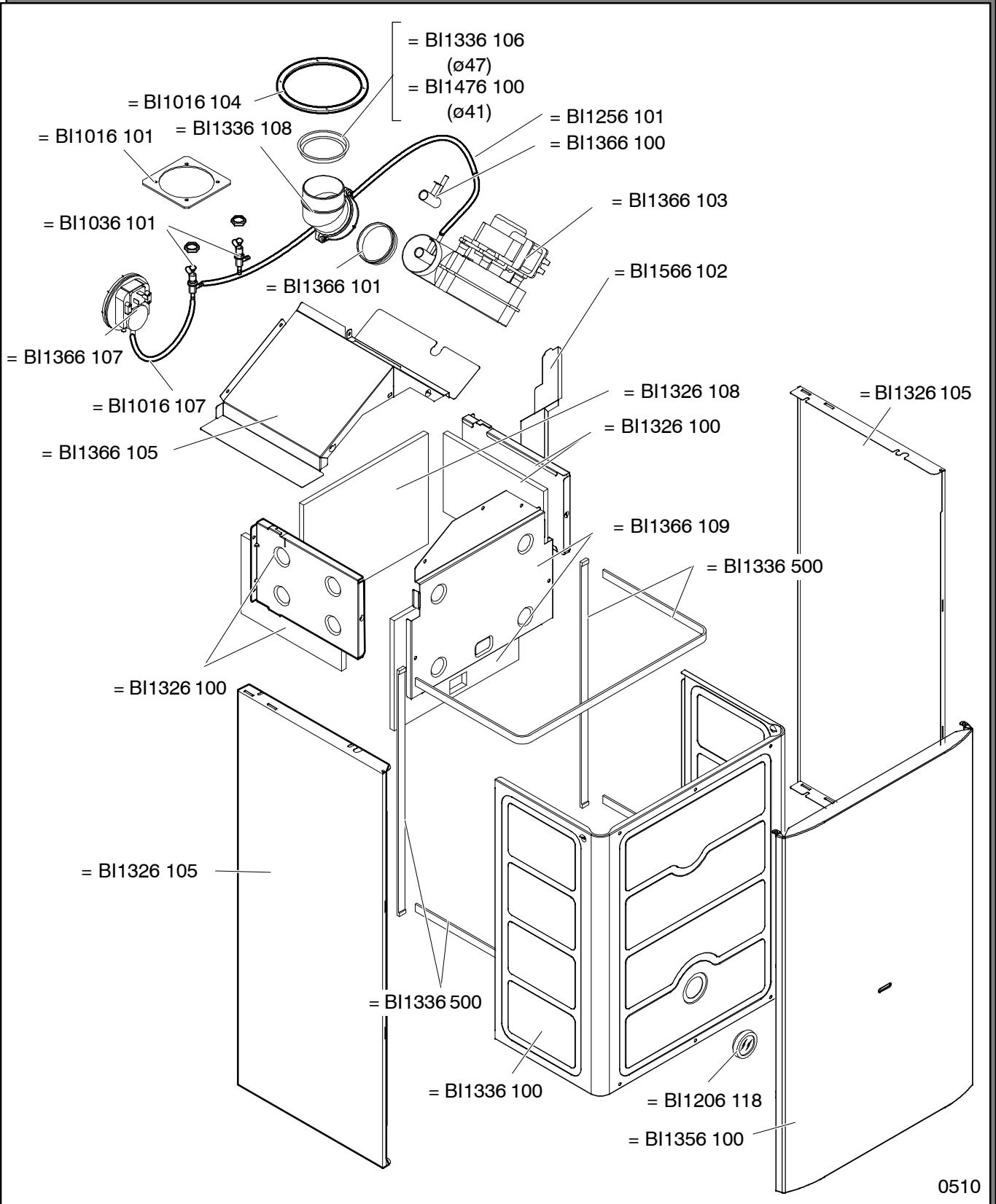

0510

M90.28CM/BX				



Part 6 - External panels, fire chamber

BI1566

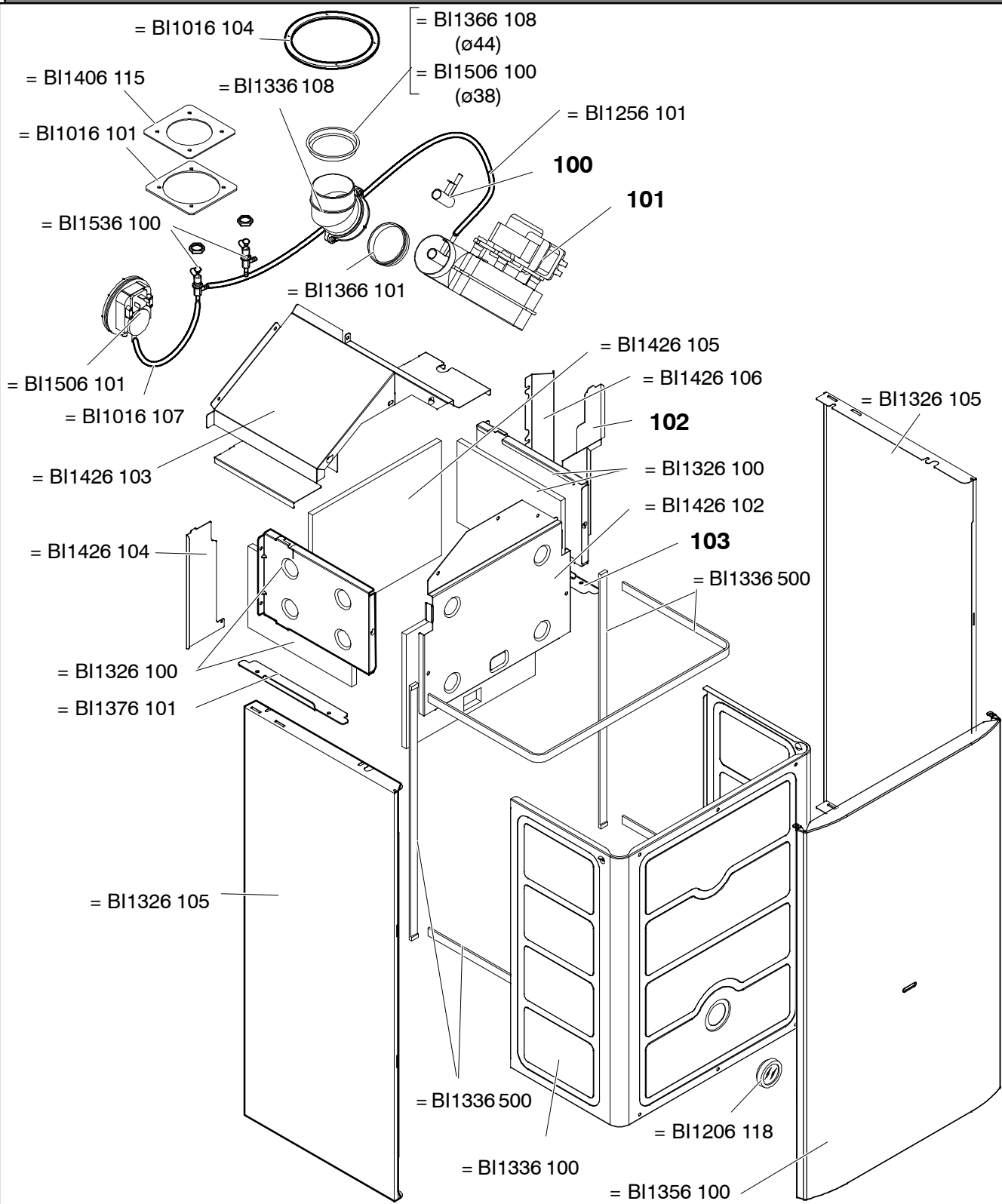

0510

M90.24CM/BX				



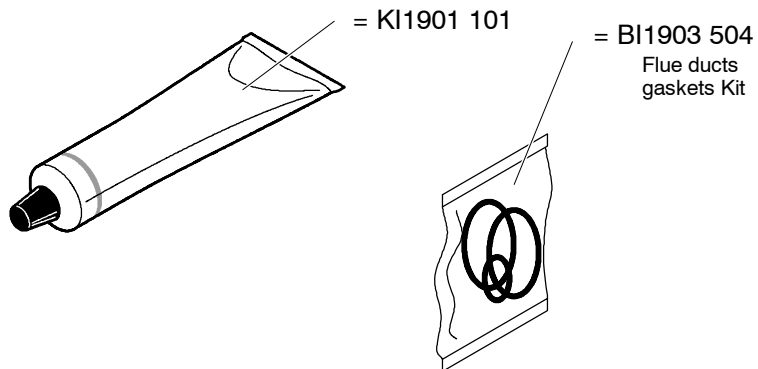

800 O-ring packing set			
Part	Pos.	N.	T. Size
BI1001	115	10	12,42 x 1,78
KI1043	144	10	18,64 x 3,53
BI1001	503	10	
KI1043	114	10	17,04x3,53
KI1001	105	10	17,13x2,62
BI1475	119	10	7x2
BI1212	112	10	17,04x4,00

BI1901 802 Flat packing set			
Part	Pos.	N.	T. Size
BI1001	107	10	P 1/4"
BI1001	109	10	P 3/8"
BI1202	105	10	P 3/8"
BI1001	106	10	P 1/2"
BI1001	108	10	P 3/4"
BI1001	105	10	P 1"

0510

M90.24CM/BX	M90.24A/BX			
M90.28CM/BX	M90.28A/BX			
M90.32CM/BX				

